

# LUNAR<sup>®</sup> HP BRAKE PADS

AD2061LHP  
FMSI<sup>®</sup># D2061.9294

OE PAD# 640 322 934 2  
WVA# 29162

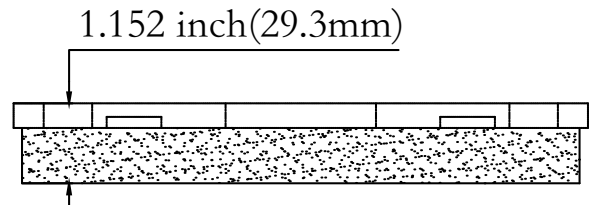
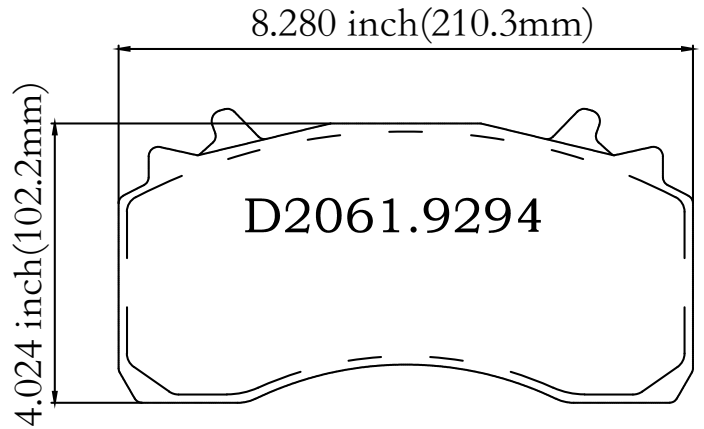

**MAKE**

Wabco

**APPLICATION**

Hendrickson

**CALIPER**

MAXXUS